

Vacc-Safe

Biomedical



Warning:
Before using this product, please read this manual carefully and keep it for future reference. The design and specifications are subject to change without prior notice for product improvement. Consult with your dealer or manufacturer for details.

version:001-7-2022

Product implementation standards
EN 61010-1 :2010/A1:2019
EN 61010-2-011:2017
EN 61326-1 :2013

EN

USER MANUAL Vacc-Safe

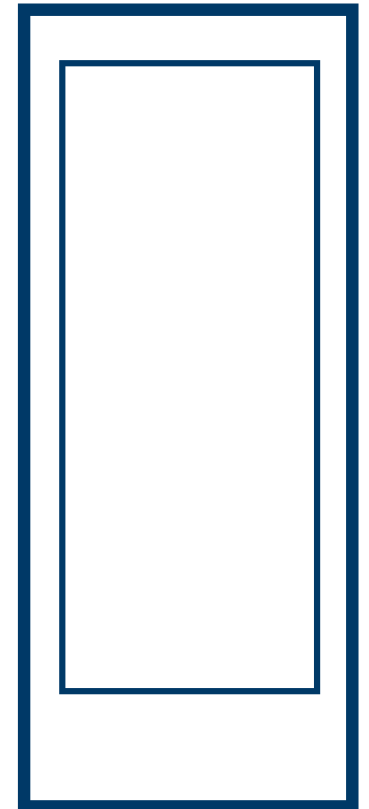

**MODEL: VS-25L518
VS-30L518
VS-40L518**

Contents

1. Product Function-----	01
2. Precautions and Safety Measures-----	02
3. Precautions for Use -----	06
4. Product Installation-----	07
5. Product Composition and Overview-----	11
6. Operating Instructions -----	12
7. Function Settings -----	15
8. Troubleshooting and Maintenance Services -----	20
9. Specifications -----	22
10. Packing List -----	23
11. Electrical Schematic Diagram-----	23
12. Service Guide -----	24
13. Warranty Card-----	26

Product Function

Series products VS-25L, VS-30L and VS-40L

Applicable to low-temperature storage of human examination samples, drugs, vaccines, biological products, reagents, etc.

Accurate Temperature Control Traceable Data

- The temperature range of the freezing chamber of the -25 °C model is adjustable from -10 °C to -25 °C.
The temperature range of the freezing chamber of the -30 °C model is adjustable from -10 °C to -30 °C.
The temperature range of the freezing chamber of the -40 °C model is adjustable from -20 °C to -40 °C.
- Equipped with USB interface as standard, the temperature data can be traced, and the test data and the temperature curve inside the box can be output at any time

Efficient Refrigeration Energy Saving Mute

- Vacc-Safe is a world-renowned compressor brand that focuses on energy saving, environmental protection, high efficiency and noise suppression.
- Stable and long-lasting performance, low noise, more uniform and stable temperature inside the box

Multiple Alarms Safe and Stable

- With perfect sound and light alarm function, it can realize high and low temperature alarm; power failure alarm; sensor failure alarm; door opening alarm; low battery alarm; circumstance temperature alarm; remote alarm, and the temperature value is set based on demand.
- The design of safety door lock ensures the safety of samples in the box.

Precautions and Safety Measures

Dear users of Vacc-Safe:

Hi! Thank you for using Vacc-Safe medical freezer. For your convenience to understand this manual, use the product, and prevent personal injuries and goods damages, please read the following instructions thoroughly.



Warning

Failure in complying matters highlighted in warning signs may cause serious casualties.



Actions or operations that must be prohibited



Note

Failure in complying matters highlighted in caution signs may cause casualties, or damages to the freezer and related property losses.



Behavior or operation that must be observed



Product with the symbol that reads "Prevent Fire, Stay Away from Fire Sources".



Product with the symbol that reads "Prevent Pinching".



Warning



Please use a power socket with a ground wire to prevent electric shock. If the power socket is not grounded, the grounding wire must be installed by professional technicians.



Be sure to place the freezer firmly on a solid and flat ground. If the ground is not stable or the place is not suitable, the freezer might be overturned or people will be injured.



If the power cord needs to be lengthened, the sectional area of the lengthened cord shall not be less than 2 mm^2 . At the same time, the length is not longer than 3 m. Otherwise, it may cause a fire or electric shock.



In case of gas and other flammable gas leakage, it is necessary to close the gas leakage valve, open the doors and windows, ventilate and exhaust, do not open any electrical switch, and do not plug in or pull out the power plug of the freezer, otherwise it may cause explosion and fire.















Only professional technicians or after-sales maintenance personnel can disassemble the freezer. Otherwise, fire may be caused.











Please use the special power supply indicated on the nameplate of the freezer, otherwise it may cause fire or electric shock.













If the use voltage is lower than 198 V or higher than 242 V, it is necessary to install more than 4000 W automatic voltage regulator suitable for motor load with the use.

-  The power cord of this freezer is equipped with a three-wire (grounded) plug, which meets the standard three-wire (grounded) socket of 10 A.
-  Under no circumstances should the grounding pin of the power cord be removed. Make sure that the power plug and socket are plugged firmly and reliably, otherwise it may lead to fires.
-  When unplugging from the power outlet, hold the power plug tightly and do not pull the wires of the power plug. If you pull the wire by hand, it may cause electric shock or fires due to short circuit.
-  If the freezer is not working properly, please unplug the power plug. It may cause electric shock or fires if it continues to operate under abnormal conditions.
-  Before any repair or maintenance of the freezer, always disconnect the power supply of the freezer to prevent electric shock or personal injury.
-  Make sure that the medicine or suspended particles inside and around the freezer will not be inhaled during maintenance, otherwise it may be harmful to health.
-  When storing toxic, harmful or radioactive materials, please use a freezer in a safe area. Improper use may cause harm to human health or the environment.
-  When the freezer is not used for a long time, unplug the power plug to prevent electric shock, leakage or fire caused by aging of the power cord.
-  If the freezer is idle for a long time in an unsupervised area, make sure that the child does not approach the freezer and that the disposal of the freezer is to be carried out by the appropriate personnel. The door should be removed to prevent accidents such as suffocation.
-  No flammable, explosive dangerous goods or volatile goods should be discharged in freezer, and do not use combustible sprays near the freezer, otherwise it may cause an explosion or fire.
-  Do not store corrosive items such as acids and alkalis in the freezer. Otherwise, the internal components or electrical parts of the freezer may be damaged.
-  Packaging plastic bags should not be placed where child can hold them, because plastic bags may cause suffocation accidents.
-  Do not climb on the freezer or put the articles on the freezer, otherwise the freezer will fall over and cause personal injury or damage to the freezer.

-  Don't use the freezer in the open air. When the freezer is wet by rain, it may cause electric leakage or electric shock.
-  Freezers should not be placed in damp places or places vulnerable to splashing water. Otherwise, electric leakage or electric shock will be caused due to insulation reduction.
-  Do not pour water directly on the freezer, otherwise it may cause electric shock or short circuit.
-  Users are not allowed to disassemble, repair or modify the freezer by themselves. Otherwise, it may cause fires or personal injuries due to improper operations.
-  Do not ground the freezer through gas pipe, power supply pipe, telephone line or lightning rod. The above grounding may cause electric shock or other hazards.
-  Do not touch any electrical parts such as power plug or any switch with wet hands, otherwise electric shock may be caused.
-  Do not put containers or heavy objects containing water on the freezer. If the object falls, it may cause personal injuries, and the outflow of water will reduce the insulation and cause leakage or electric shock.
-  Do not insert metal objects such as nails or wires into any openings and gaps of the freezer or into any vent used for internal air circulation, otherwise electric shock or injury may be caused by the above objects contacting with moving parts.

 **Note**

-  There should be no obstruction around the freezer, and the ventilation should be smooth.
-  It is necessary to check the freezer setting when restarting the freezer after power failure or power off.
-  Changes in settings may damage stored items.
-  Once the power of the freezer is cut off, it will take more than five minutes to turn it on again to avoid damage to the compressor or system.
-  Gloves should be worn during maintenance to not to touch the sharp edges or corners and avoid the injuries to personnel.
-  Hold the handle to close the door so that the door will not catch your fingers.
-  When moving freezers, the inclination angle should not be more than 45 degrees.

-  When transporting the freezer, be careful not to trip over freezer to prevent damage to freezer or personal injury.
-  Please do not use the door handle to lift or carry the equipment, in case of injury to the freezer or personal injury.
-  The refrigeration circuit must not be damaged.
-  Do not use electrical appliances in the storage room of freezers except for the type recommended by the manufacturer.

Precautions for Use

- ★ Before putting articles into the equipment, please make sure that the temperature in the storage room has reached the set temperature, and then put the articles in batches. The volume of the articles in the box should not exceed 1/3 of its volume at a time to prevent the temperature from rising too much.
- ★ The temperature display value of the equipment is to show the temperature at the temperature sensor in the storage room. There is a certain gap between the displayed temperature and the actual temperature at the center of the equipment when the equipment just runs, but as the equipment enters a stable state, the displayed temperature will gradually approach the actual temperature.
- ★ The equipment box body is provided with a detection hole so as to lead out the test line in the box during the test. After the test line is led out, it is necessary to plug the test hole with insulating material again, otherwise the temperature in the box may not reach the set temperature value, and condensation will appear around the outside of the through hole.
- ★ Please use diluted neutral cleaner to clean the equipment, and do not use brushes, acid, gasoline, soap powder, polishing agent or hot water to clean the equipment, otherwise the painted surface and plastic rubber parts may be damaged. Attention: Do not use volatile solvents such as gasoline to clean plastic and rubber parts.
- ★ When the device is not in use for a long time, cut off the power supply and turn off the battery.
- ★ Each time you access the items, please try to reduce the time to open the door to avoid large fluctuations in temperature and humidity inside the box.
- ★ After the door is opened, the temperature inside the box will rise sharply in a short time. This is normal, and the situation will be restored within 1 hour after the door is closed.

Product Installation

Installation environment -----

- ★ The freezer is only for indoor use, with second pollution level and second type of over-voltage
- ★ Ambient temperature is within 16°C-32°C, and recommended temperature is within 18°C-25°C. If necessary, air conditioning system should be used.
- ★ Environmental humidity: lower than 80%Rh.
- ★ Avoid heavy dust.
- ★ Avoid mechanical sway or vibration.
- ★ The altitude of working position of freezer is lower than 2000 m.
- ★ Input voltage: 220 V±10%.
- ★ The freezer is sensitive to ambient temperature. When installed in other environments than the one aforesaid, the freezer can't operate normally. Please improve the environment before use.
- ★ It is prohibited to install the freezer in an open environment. When the freezer is wet by rain, it may cause electric leakage or electric shock.

Installation Site -----

- ★ Do not install the device in a narrow and confined space. Install it in a place that can ensure its normal access to avoid damage to storage goods by maintenance difficulties and delayed repair in case of device failure.
- ★ The installation floor must be solid, flat, non-combustible and able to bear the weight of the device during operation.
- ★ Provide good ventilation and avoid direct sunlight.
- ★ Each device needs to use a separate power outlet. Please ensure that the power outlet should withstand a current of ≥ 10 A, and the plug and power outlet are firmly connected.
- ★ Check the working voltage before use. In areas with unstable voltage, a voltage stabilizer suitable for device load should be considered for voltage stabilization, and the power of the voltage stabilizer should be greater than 4000 W to ensure that the input voltage requirements in the installation environment can be met.

★ Device should be reliably grounded. If the power outlet is equipped with grounding wire, check whether it is normal before use. If the power outlet is not grounded, the grounded wire must be installed by professional technicians.



- ★ Do not ground the freezer through gas pipe, power supply pipe, telephone line or lightning rod.
- ★ After installation, the power plug must be accessible, so that the power cord can be unplugged in time in case of emergency. The vent of the freezer should not be covered by any object.



- ★ As the ambient temperature has a great impact on the device, if the above environmental requirements cannot be met, the device may not be able to operate normally. Please improve the environment before using the device; the device is working in intermittent operation.
- ★ Ambient storage and transportation temperature: $-40^{\circ}\text{C} \sim +60^{\circ}\text{C}$, Relative humidity: 10% ~ 90%

Preparation Before Use-----

1. Remove the outer packaging of all products (including the protective foam in the packing box).
2. Check the random accessories; please check the contents in the box according to the packing list. If there is any discrepancy, please contact the after-sales service in time.
3. Placement conditions: a gap of at least 10 cm should be left around the freezer to facilitate ventilation and heat dissipation.
4. Lock the front rollers to ensure that the freezer does not move during use.



- ★ Don't put the plastic bags in the place where child come into contact, so as to prevent suffocation accidents.

First Power On -----

When using the device for the first time, please follow these steps:

1. After the device is placed, leveled and cleaned, it needs to be left for more than 24 hours before it is connected to the power supply to ensure the normal operation of the device.
2. Under no-load condition, connect the power cord to a special socket with appropriate specifications.
3. After turning on the power, observe whether the machine is running normally.
4. Check whether the operating temperature of the device reaches the required temperature, observe whether the device is normally on and off for more than 24 hours, and put a small amount of articles in the storage room after confirming that the performance is normal.
5. Please store items in batches, which is not exceeding 1/3 of the box volume at a time. The next batch of goods can only be put in after the device is shut down for more than 12 hours.
6. Try not to open the door during the cooling process, otherwise it will cause the temperature to rise.

Operation After Power Failure -----

The device has the memory function for the set value. When the power is restored after the power failure, the device will continue the operation before the power failure.



- ★ Once the power of the freezer is cut off, it will take more than five minutes to turn it on again to avoid damage to the compressor or system.
- ★ When the equipment is not used for a long time, the power should be cut off and the battery should be turned off at the same time (for projects with batteries).
- ★ Please ensure that children will not approach the medical freezer and use it as a toy if it is left unattended in an unsupervised area for a long period.



- A special person shall be responsible for the operation of this product, and check and record it every day. If the temperature in the cabinet is too high or too low, the goods shall be transferred to other freezer, and the goods shall not be stored again until the fault is eliminated.

- This product is a medical freezer

VS -25L Series Temperature of the freezer ranges from -10~-25°C and is adjustable

VS -30L Series Temperature of the freezer ranges from -10~-30°C and is adjustable

VS -40L Series Temperature of the freezer ranges from -20~-40°C and is adjustable

Please make sure that the stored items are consistent with the environment in the freezer, so as to avoid damage to the items and economic losses.

- Due to the refrigeration inertia, the display temperature and humidity of this product are different from the actual temperature and humidity in the box, which is a normal phenomenon.



- All freezers are for preservation. Hence, it is strictly forbidden to put too many relatively hot items at one time, which will cause the compressor not to stop for a long time, the temperature drops slowly and affects the service life of the compressor. Stuff must be put in batches, and the temperature should be lowered step by step until it falls to the required temperature!
- The refrigeration circuit shall not be damaged.
- Unlicensed electrical appliances are not allowed to use inside the freezer.

Product Composition and Overview



- * Due to the improvement of products and different models, the actual products may be different from the schematic drawings. Please refer to the real objects! The sketch is only used for the description of the functional parts.
- * It mainly consists of refrigeration, electric control and alarm system, box, door and accessories (container and shelf).

Operating Instructions

Operation and Display Panel

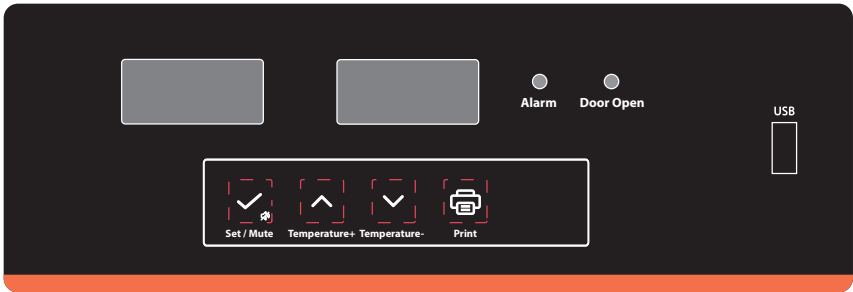

Function Introduction

Temperature display window: under normal operation, the upper chamber temperature and lower chamber temperature are displayed respectively in °C.

Door-opening indicator: the indicator lights up when the upper or lower chamber door is open. After more than 1 minute, the door opening alarm indicator lights up and the buzzer gives an alarm. "Door1" flashes in the display window in the upper chamber when the upper chamber door is not closed. "Door2" flashes in the display window in the lower chamber when the lower chamber door is not closed.





Fault indicator light: the indicator light is off when the product is running normally and is on during abnormal operation.





(Printer option): The system can retain 7 days of data for printing. Press down the print button to print the temperature within the set time period.



Reduce the parameter value in the parameter setting mode. For example, reduce the set temperature when setting the set temperature. Press and hold the  key when setting the parameter value, the parameter can be reduced quickly.





-  Increase the parameter value in the parameter setting mode. For example, increase the set temperature when setting the set temperature. Press and hold the  key when setting the parameter value, the parameter can be increased quickly.
-  Setting / Mute key: when there is no alarm state and the key is not unlocked, press down the  key, the normal display resumes after displaying the ambient temperature for 5 seconds. Press and hold the  key for 3 seconds to access the user menu in the unlocked state.



When the buzzer gives an alarm (including cabinet over-temperature alarm, door opening alarm, sensor fault alarm, etc.) and the button is not unlocked, press down  for the first time, the buzzer stops sounding and the normal display resumes after displaying the ambient temperature for 5 seconds (Pressing the mute button can only turn off the buzzer for this abnormal state alarm. If the fault is not removed after 5 minutes of muting, the buzzer will alarm again.). Press down  again, and the buzzer alarms. After displaying the ambient temperature for 5s, display of cabinet temperature and alarm status will resume.

When the key is unlocked,  can be used as a setting key. When setting the parameter mode in the unlocked state, press this key to display the parameter value and parameter name. If the key is pressed down for 3 seconds, the setting is saved and the normal screen will be returned to.



USB interface: Automatic USB data export: when the USB flash disk is connected to the USB interface, the buzzer will sound once connecting success. The upper digital tube will display "USB", and the lower digital tube will display "on". PDF files of the data of the current month and the previous month will be generated in the USB flash disk. After the data transmission is completed, the buzzer will sound once, and the digital tube will display "End". After 6s, the digital tube will return to normal display.



 **Note:** "USB", "on", and "end" prompts are not displayed when the amount of data is small.

Manual export of USB data: when the key is unlocked and no file is being generated, connect the USB flash disk and press the  key for 3s until the digital tube displays "d01". Press the  or  key to adjust "d00 ~ d12". Press the  key, and the file generated this time (d00) or the PDF file with the data recorded in the forward month (1-12) is cancelled inside the USB flash disk.

 **Note:** When the digital tube flashes and displays "LoF", the recorder is not started. Press down the  and  keys simultaneously for 3 seconds, "LoF" disappears and the recorder starts.

Independent closing of the upper or lower chambers: it is used for inter-chamber deactivation, or separate frosting.

In the normal operation mode, first unlock the panel, and press and hold the keys  and  together to close the upper chamber. The upper digital tube flashes and displays "off".



In the normal operation mode, first unlock the panel, and press and hold the keys  and  together to close the lower chamber. The lower digital tube flashes and displays "off".



To modify the time of the data recorder system:

The system time can be set when the machine is powered on again after power failure. The digital tube displays "n" after the system completes the self test. If there is no operation for 60 seconds, it will automatically exit and enter the normal display.

Menu	Menu Description	Setting Range	Note
n	Set the time of recorder module - year	10~50	22 represents 2022
y	Set the time of recorder module - month	1~12	--
r	Set the time of recorder module - date	01~31	--
S	Set the time of recorder module - hour	00~23	--
F	Set the time of recorder module - minute	00~59	--
Pt	Printing interval	0~240	20min
SCY	Temperature data recording cycle	0~240 0: shielded recorder	10min

Press the  key to switch parameters n-y-r-s-F-Pt-SCY

Press the  key or the  key to set the parameter value. After setting, press and hold  to save the parameter.

Note: Operation to modify the time and recording interval will cause the recorder data to be cleared, and the data recorder will be restarted. The digital tube will display "LoF". To eliminate it, refer to Recorder Startup Operations. When the digital tube flashes and displays "LoF", the recorder is not started. Press down the  and  keys simultaneously for 3 seconds, "LoF" disappears and the recorder starts

View the maximum and minimum values





The MAX1 and MAX2 parameters in the user menu, as well as the MIN1 and MIN2 parameters, display the maximum and minimum temperature values within the current time period





Battery voltage check

Press down the keys  + , the digital tube displays the battery voltage

Function Settings

User Parameter Setting

Unlocking: In the normal operation state, press and hold the  and  keys for 3 seconds, the upper digital tube displays "PS1" and the lower digital tube displays the parameter code "0000". Press the  key, enter the password "0005" (When entering the user menu password, enter "0099" to restore the key lock password to the default "0005"), and it will be unlocked. After unlocking, press and hold the  key for 3 seconds, and the digital tube displays the parameter code "MAX", thus entering the setting to adjust the parameters.

1. Scroll through the parameters using the  key, and the display order is MAX1 -MIN1-MAX2-MIN2-CLR-SEt1- H01-L01-SEt2-H02-L02-n-y-r-S-F-Pt-tH1-P1-PS1-b1-b2
2. Increase or decrease the value using the  and  keys;
3. Press the  key to temporarily store the modified value and return to the display parameters
4. If you need to modify other parameters, repeat steps 1~3.
5. Press and hold the  key for more than 3 seconds to store the modified parameter and return to the displayed parameter category

Serial Number	Menu	Parameter Range	Recommended Setting Value	Note
1	MAX1	---		Upper maximum temperature in the current time period
2	MIN1	---		Upper minimum temperature in the current time period
3	MAX2	---		Lower maximum temperature in the current time period
4	MIN2	---		Lower minimum temperature in the current time period
5	CLR	0~1	1	0: Clear the record of the maximum and minimum temperature in the current time period 1: The record of the maximum and minimum temperature in the current time period will not be cleared
6	SEt1	MD-25L series: -10~-25°C VS-30L series: -10~-30°C VS-40L series: -20~-40°C	-25 °C -30 °C -40 °C	Upper chamber temperature setting value
7	H01	0.0~10.0	5	Upper deviation on high temperature alarm of the upper chamber
8	L01	0.0~10.0	5	Lower deviation on low temperature alarm of the upper chamber
9	SEt2	MD-25L series: -10~-25°C VS-30L series: -10~-30°C VS-40L series: -20~-40°C	-25 °C -30 °C -40 °C	Lower chamber temperature setting value
10	H02	0.0~10.0	5	Upper deviation on high temperature alarm of the lower chamber
11	L02	0.0~10.0	5	Lower deviation on low temperature alarm of the lower chamber

Serial Number	Menu	Parameter Range	Recommended Setting Value	Note
12	n	---	--	Check the current date - year
13	y	---	--	Check the current date - month
14	r	---	--	Check the current date - day
15	S	---	--	Check the current date - hour
16	F	---	--	Check the current date - minute
17	Pt	0~240 minutes	20	Printing interval
18	tH1	20.0~50.0	32	Ambient temperature alarm value
19	P1	1 ~ 5	5	Door heating mode selection
20	PS1	0 ~ 9999	0005	Password setting of user menu
21	b1	---	--	Hardware version
22	b2	---	--	Software version

Fault Alarm Code:

Alarm Code	Fault Description
H01	High temperature alarm of the upper chamber
L01	Low temperature alarm of the upper chamber
H02	High temperature alarm of the lower chamber
L02	Low temperature alarm of the lower chamber
H03	High ambient temperature alarm
door 1	Door-opening alarm of the upper chamber
door 2	Door-opening alarm of the lower chamber
PF	Power failure alarm
BL	Low battery alarm
EE	Display board communication fault
E1	Sensor 1 of the upper chamber alarms
E2	Sensor 2 of the upper chamber alarms
E4	Temperature sensor of the lower chamber alarms
E5	Temperature sensor 5 of the upper chamber alarms
E6	Ambient temperature sensor alarms
Er	Recorder not connected
Pr	When error generating file from USB flash disk
LoF	Recorder not started

Maintenance and Care



- ★ To prevent electric shock or personal injuries, please make sure that power is disconnected before having any repairs or maintenance on the device.
- ★ When maintaining the device, make sure that you do not inhale surrounding medications or suspended particles that could damage your health.



- ★ Do not directly sprinkle water on the freezer, so as to avoid the decline of insulation performance of electrical components and rust of metal parts.
- ★ Do not use hot water, corrosive detergent or organic solvent to clean the freezer.
- ★ Do not put heavy objects on the top of the device to avoid deformation of the device under pressure.

Device Maintenance

Cleaning and maintenance:

- 💧 The interior of the freezer should be cleaned once a month. Regular cleanings can keep the freezer fresh.
- 💧 Use a dry cloth to wipe off a small amount of dust outside and inside of the freezer as well as that on all accessories. If the freezer is dirty, use a cleaning cloth soaked with neutral detergent to remove the dirt, wipe off the residual detergent with a wet cloth, and then wipe it again with a dry cloth.
- 💧 Do not dump water on the shell of the freezer or inside the freezer. Otherwise the insulation of electrical appliances may be damaged, and faults may occur.
- 💧 The compressor and other mechanical parts are completely sealed without lubrication.

Device Deactivation

Discontinuation: If the equipment is stored in an unsupervised area for a long time and is not used, the power supply should be cut off and the inner and outer surfaces of the box should be wiped clean with a warm and wet soft cloth, and then dried and sealed; It is necessary to ensure that the equipment is locked, and that child cannot open the door to prevent accidents such as suffocation.

End-of-life: When the equipment reaches the end of its service life, it should be scrapped and must be handed over to qualified professional recycling organizations for scrapping and disposal in accordance with local regulations and ordinances; non-professionals should not disassemble or disassemble the equipment without authorization; Scrapped equipment should be placed in designated areas that are inaccessible to child to avoid danger.

Troubleshooting and Maintenance Services

When there is a failure in the product, please check and handle it according to the following table. If the situation cannot be changed, please inform Vacc-Safe Biological Service Center in time. We will serve you wholeheartedly to avoid any loss to you.

Malfunction	Troubleshooting
Freezer does not work	Check whether the input power meets the requirements
	Whether the plug and the socket are in poor contacts
	Whether the input and control lines are faulty
	Whether the voltage is too low

Malfunction	Troubleshooting
<p>The cooling effect is not obvious, and the temperature exceeds the standards</p>	Whether too many or overheated items are stored
	Whether there is a certain gap between the stored items
	Whether there is direct sunlight or other heat source radiation
	Whether the door is open frequently
	Whether the ambient temperature is too high
	Whether the air duct is blocked
<p>Excessive noise</p>	Whether the freezer is placed stably
	Whether a part of the cabinet is in contact with external objects or walls
	During use, it is normal for the actual noise to differ from the marked value due to the influence of loaded items, ambient noise, unclosed doors, compressor opening and closing, etc.
<p>The alarm lamp flashes and the buzzer gives an alarm.</p>	Whether the objects are just put in and the temperature is not stable. After operating for some time, the alarm disappears.
	Whether the door alarm is caused by not fully closing the door. Close the door again
	Whether the battery is low. It will return to normal after running for some time
	Whether the temperature exceeds the standard

Specifications

Name	Medical Low-Temperature Freezer
Model number	VS-25L518/VS-30L518/VS-40L518
External dimensions	866*811*1920
Internal dimensions	The upper chamber: 680*620*650 The lower chamber: 680*620*650
Effective volume	The upper chamber 259L The lower chamber 259L
Door body	The upper chamber: Foaming door The lower chamber: Foaming door
Foamer	Cyclopentane
Shelf	The upper chamber: 6 drawers The lower chamber: 6 drawers
Cooling mode	Direct cooling
Shell plate / Inner plate	PCM/painted steel plate
Temperature controller	Computer controller
Refrigerant	The upper chamber: R290 70g The lower chamber: R290 70g
Illumination lamp	None
Net weight	142Kg
Rated supply voltage	220V 50Hz
Operating power/rated current	450W/3.8A
Electric shock resistance type	I
Power connection mode	Y
USB functions	With
Noise	58dB

Packing List

Model Number	Instruction	Key	Door Handle
VS-25L518	1	2	2
VS-30L518	1	2	2
VS-40L518	1	2	2

- ★ The warranty card and certificate are included in the instruction and the specific packing list shall prevail in accordance with the real product.

Electrical Schematic Diagram

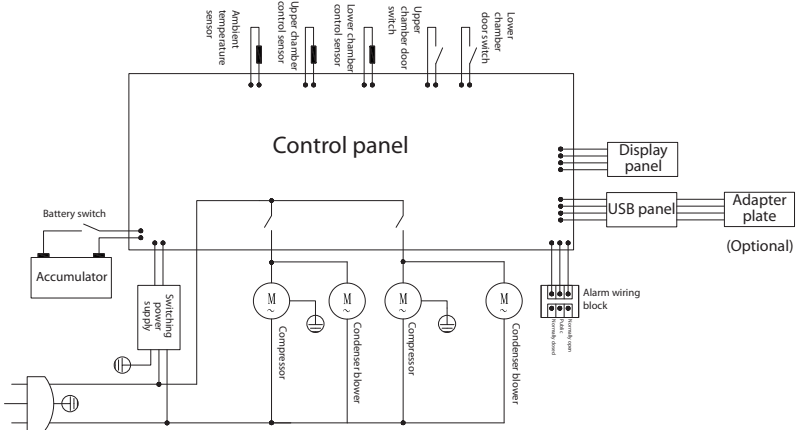

VS-25L518/VS-30L518/VS-40L518

- ★ The operating capacitance of the compressor is optional, and see the selection of the complete machine for details

Service Guide

Notes

- 1 The warranty card together with the purchase invoice, as the warranty certificate of the product, shall be properly kept by the customer.
- 2 From the date of purchase, when the product is not repaired and disassembled by the customer in the period of "three guarantees", there is a failure caused by manufacturing quality. With the appraisal of the customer service department or authorized maintenance department, the customer with warranty card and purchase invoice, can be provided with warranty service in accordance with State Economic and Trade Commission (part of regulation of the responsibility for repair, replacement and return of the commodity) ("new three guarantees" provisions).
- 3 The product is beyond the scope of the warranty under the following circumstances, including improper transportation, use, maintenance and storage by the user or damage caused by disassembly of the repairman who is not responsible for "three guarantees"; Without warranty card and valid invoice; The warranty card model's inconsistency with the model of the product to be repaired or the alteration of the warranty card; Damage caused by force majeure.

Define the warranty period

From the date of purchase, the complete machine can enjoy free warranty within the warranty period.

Conditions of free warranty

- 1 They should be the users who have purchased Vacc-Safe medical freezer series products and have gone through warranty registration procedures.
- 2 The warranty certificate (warranty card) should be held and the name, model number, bar code of the product to be repaired must be consistent with those on the warranty card; If a valid warranty card cannot be provided, the warranty, according to the date of the factory on the bar code of the machine, is extended for 6 months on the basis of the warranty period.
- 3 It must be within the warranty period.
- 4 It should be the failure caused by non-human factors.
- 5 The expected service life is 10 years.

Production date: please see the label on the freezer.

Product warranty period

Whole Machine	Main Components	Note
Two years	Two years	The main components include: compressor, main control panel, display control panel, temperature controller, evaporator, condenser, solenoid valve, filter, capillary, fan motor.

(Note: if there are a separate warranty agreement, it shall be performed based on the agreement)